

COPPER SCULPTURES INC.
 5230 Lakeland Drive
 Brandon, MS 39047

Call 601-992-9955 To Place Order

MBAE-2

8" Steel Mailbox - *Copper Powder Coat*
 Post & Bracket - *Essex Green Powder Coat*

Solid Copper Plasma-cut Address
 Plaque

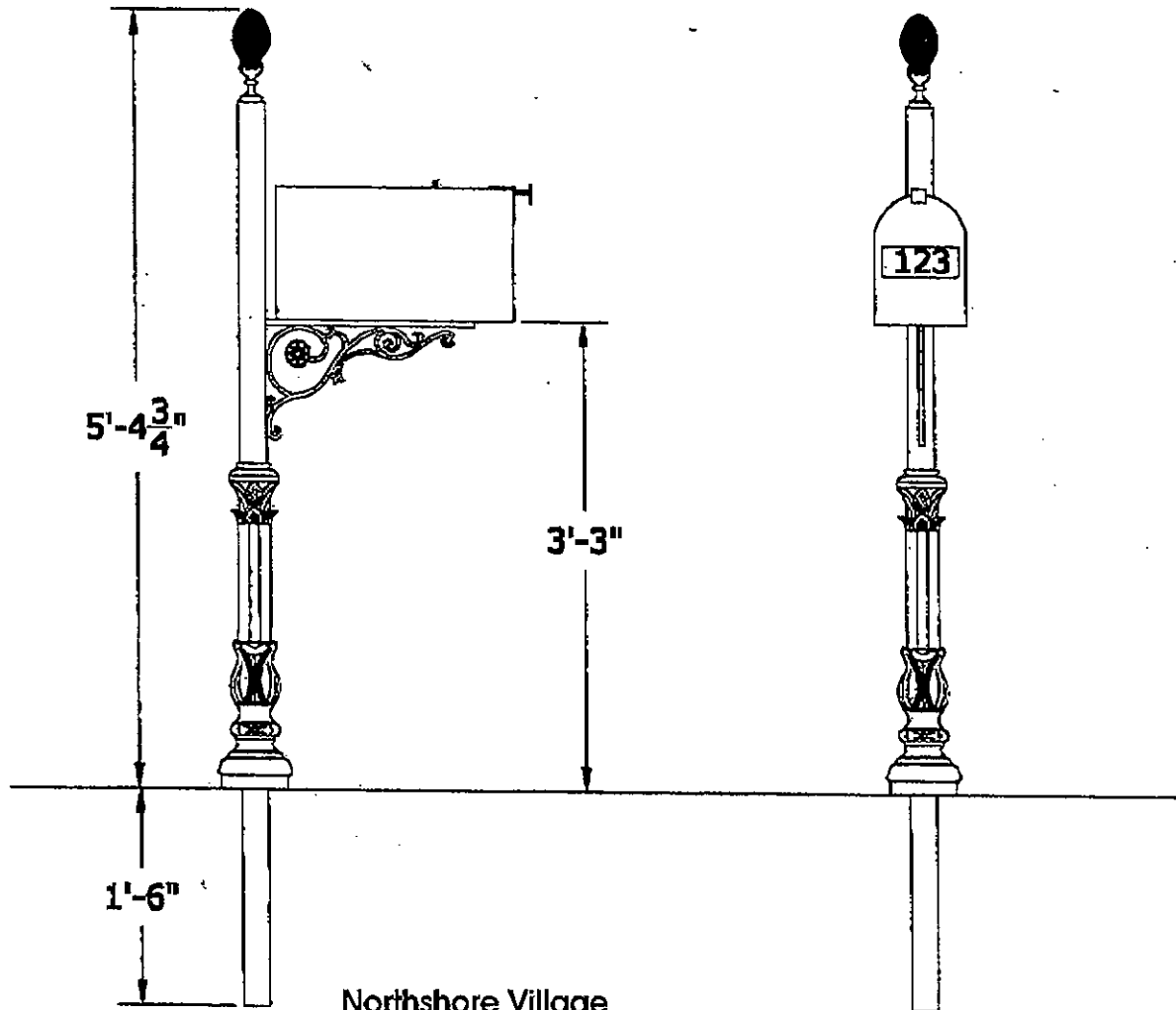

Northshore Village
 Mailbox & Post
 5 or More Per Order...\$301.00 + tax
 <5 Per Order...\$325.00 + tax
 Optional Installation...\$40.00 + tax

COPPER SCULPTURES INC.			
ORDER TOTAL			
ORDER NO.	3224	DATE	
DATE	1-1-02	CITY AND STATE	MEMPHIS

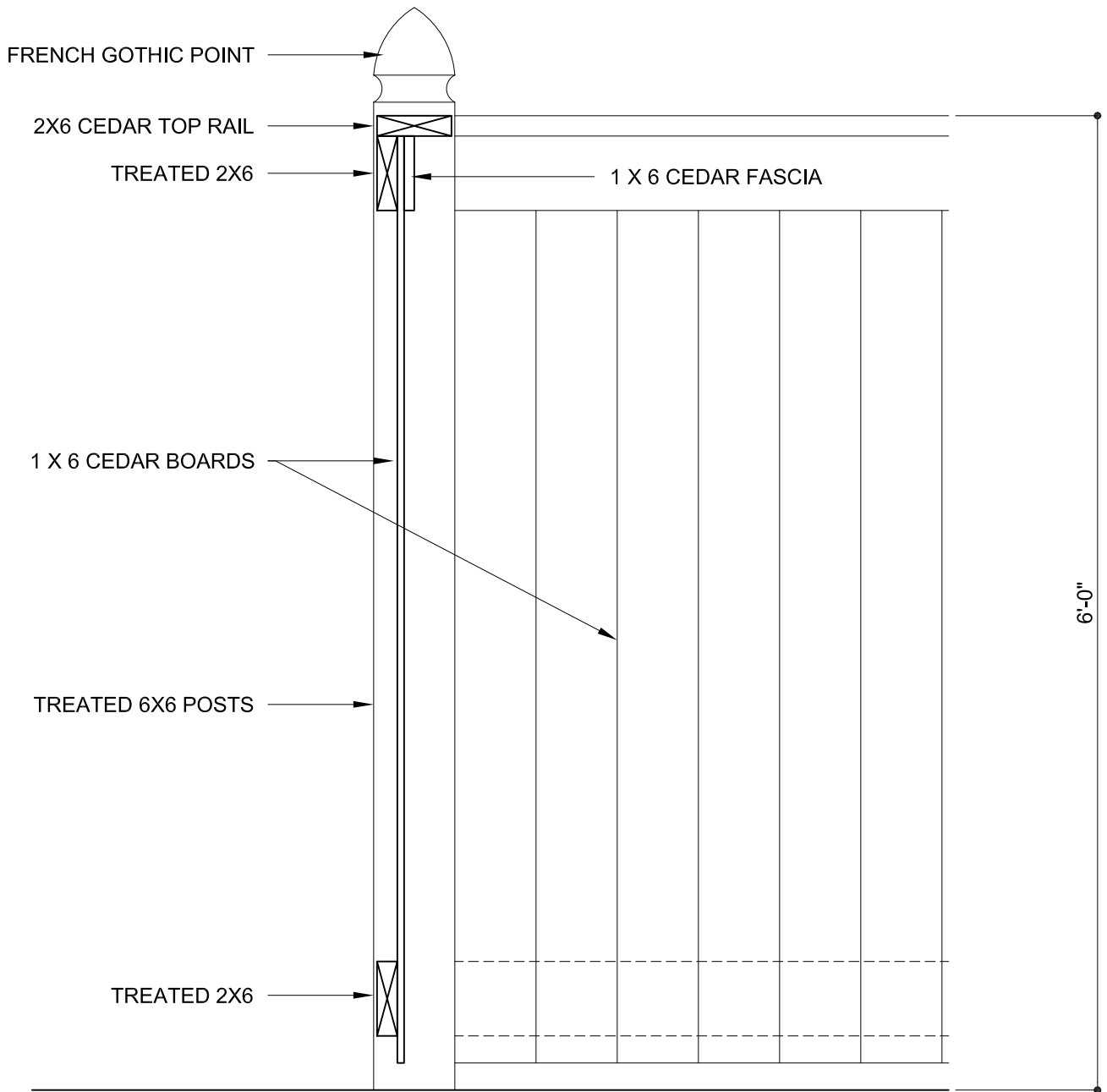

Northshore Village Standard Fence

scale: 1"=1'-0"



Northshore Village Property Owners Association, Inc.

Covenant Amendment

To: All Homeowners
From: Larry Green, President
CC: Jim Martin, Attorney at Law
Date: 5/10/2010
Re: Architectural Shingles

The property in our neighborhood is covered by restrictive covenants, which were implemented to assure the preservation of property values. It essential the Architectural Control guidelines within our covenants be reviewed from time to time and revised to adopt standards that establish uniformity and advocate an up to date and consistent appearance for the subdivision. It was for this reason standards with respect to the replacement of mailboxes and fences were adopted at the annual meeting in 2007.

In accordance with a recommendation by the Architectural Review Committee, the Board of Directors recently approved an Architectural Control requirement for roofing material. This requirement is being implemented as a result of research, discussion, and a consensus of opinion the new standard will sustain the real estate market values of our homes. The majority of homes in the subdivision are already in compliance with this standard.

The new standard requires; roofing material have an architectural dimensional effect, applies to future roof replacement, and becomes effective with this notification. Composition or 3-tab shingles will no longer be permitted. The Architectural Review Committee must approve other roofing materials.

Please remember that pursuant to Article X of the Covenants, Architectural Review Committee approval is required prior to beginning any improvements. If you have any questions with respect to Architectural Control, the committee members are Bill Harris (Chairman), Uriel Pineda, and Sharla Bachelder. Their contact information can be found in the membership directory.

The elected officers and board members of the Association appreciate your support in compliance with improvements to the quality of our subdivision and invite your ideas for additional improvements.